

WEIGH-TRONIX®

- Factory Mutual Approved Control Document 29274
- Legal-for-trade Class III/IIIL 10,000 divisions
- Stainless steel NEMA 4X enclosure
- 1" high digits



WI-150 Ultra Low-power Weight Indicator

WI-150 ULTRA LOW-POWER WEIGHT INDICATOR

MENU

Accesses menus and moves among choices in a menu.

PRINT SELECT

Sends a print command and selects menu items.

TARE +/-

Enters a pushbutton tare in gross/net operation. During data entry this key toggles between positive and negative values.

GROSS / NET

Accesses the gross/net weighing mode from any other function, and toggles the unit between gross and net weights, assuming there is an active tare weight.



UNITS

Changes the unit of measure during operations mode and inserts a decimal point when keying in values.

0 to 9 keypad

enters numbers and specifies tare and cutoff registers.

OFF

Puts the battery-pack model indicator into an ultra-low power consumption mode called the sleep mode.

ON

Wakes the battery-pack model from sleep mode. (PS-150 powered units are always on.)

ZERO CLEAR

Zeros the scale in gross/net weigh mode. Also clears keyed-in digits on the display before they are accepted.

Features and benefits

Factory Mutual approved—

The WI-150 Weight Indicator has been tested and accepted for hazardous environments including the following location classifications: Class I (gases), Divisions I and II; Groups A, B, C, and D; Class II (dusts), Divisions I and II, Groups E, F and G; and Class III (fibers), Divisions I and II.

Versatile—

The WI-150 can operate from a BP-150 Battery Pack, PS-150XP continuous power source, or from a PS-150 AC to DC Power Supply with barrier located in a safe area. Use the indicator for simple scale operations or link it with computers, printers and other data-gathering devices.

Front panel configuration—

All calibration and programming is done through the front panel.

Menu driven—

Simplifies the operation of the WI-150. Just press the MENU key and cycle through the available function choices. Adapt the menu to your operation during configuration. Select only the options you want to appear under MENU key.

Security code—

Protects configuration, calibration, and user data from unauthorized tampering.

Selectable units of measure—

Configure the WI-150 to measure in pounds, kg, or even gallons with programmable density.

Selectable tare operation—

Select pushbutton tare and/or up to 10 keyboard tare registers.

Battery saver—

Low-power A to D converter for the battery pack version. Conserves battery life with one-eighth duty cycle load cell drive.

Sleep mode—

Extends battery life on battery pack versions. Programmable for virtually any interval of scale idleness.

Battery backed up RAM—

Protects tare and pushbutton zero information. EEPROM stores configuration and calibration data.

Options

Fiber optics data interface card—

Installs in the WI-150 Indicator to facilitate transmission of signals through a fiber optics cable to receiving circuitry in a safe area. Includes time and date.

WI-150 Specifications

Enclosure:

NEMA 4X, water-tight, stainless steel 7³/₄" high x 9¹/₈" wide x 6" deep (19.6 cm x 23.2 cm x 15.2 cm)

Display:

7-segment LCD, 8 digits, 1.0-inch high with 10 annunciators

Capacities:

Programmable to any number between .00001 and 999,999

Hazardous location classifications:

Class I, Divisions I and II, Groups A, B, C, and D; Class II, Divisions I and II, Groups E, F, and G; Class III, Divisions I and II

Entity parameters:

V_{max} = 19 V, I_{max} = 450 mA, C_i - 0.24 uF, L_i - 0 mH

Display rate:

Selectable to 1, 2, or 5/second

Accuracy:

Span: ±5.0 ppm/°C

Zero: ±0.66 uV/°C (-10 to 40°C)

Span: ±10 ppm/°C

Zero: ±0.13 uV/°C (-30 to 60°C)

Linearity:

±0.005% of capacity, maximum

Repeatability:

±0.005% of capacity, maximum

Hysteresis:

0.005% of capacity, Maximum

Voltage requirements:

+5.6 to 13.5 volts DC

Resolution:

Sealable to 10,000 divisions.

Higher resolutions available

Increments:

Programmable to any size between .00001 and 20,000 lb/kg

Controls:

| | |
|-------|--------------|
| MENU | PRINT/SELECT |
| TARE | GROSS/NET |
| UNITS | ZERO/CLEAR |
| ON | OFF |

Annunciators:

| | | |
|---------|--------|-------|
| Gross | Tare | Net |
| Low Bat | Motion | Print |
| gal | lb | kg |
| Zero | | |

Excitation:

Drives up to eight 350-ohm Weigh Bars or twenty-two 1000-ohm Weigh Bars

Environment:

-10 to 40°C (14 to 104°F)
10 to 90% relative humidity

Shipping weight:

14 lb (6.4 kg)

HAZARDOUS AREA

The AC-powered WI-150 Indicator and an approved weighing device are located within the hazardous area.

Factory Mutual Control Document 29274 provides a list of all weight sensors and junction boxes that Factory Mutual has approved for operation as a system with the WI-150 in hazardous environments.

For operation with peripheral equipment, the WI-150 must include the optional fiber optics interface card.

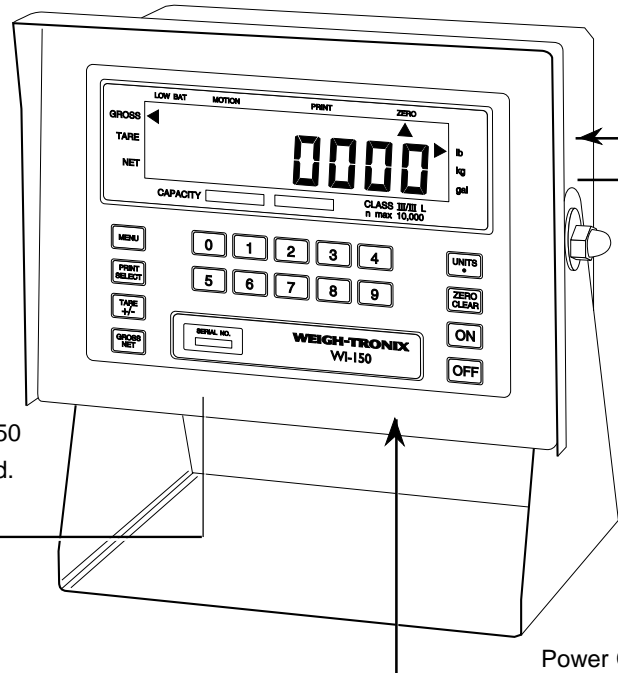

Scale

Power Cable

Fiber Optic Cable

Fiber optics cables carry scale information from the WI-150 Indicator to either the SC-150 Control Unit or the Fiber-Link signal converters located in the safe area. The cable has a dual layer of protection. The outside polyethylene jacket protects cable from moisture, cracking and surface nicks. An inner Kevlar strength member surrounds the fibers, giving the cable the rigidity to keep fibers from being damaged by overbending.

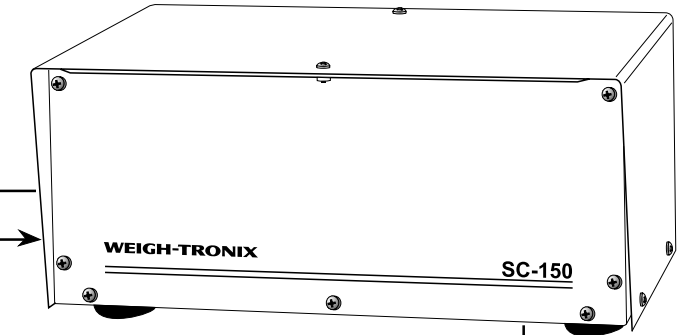
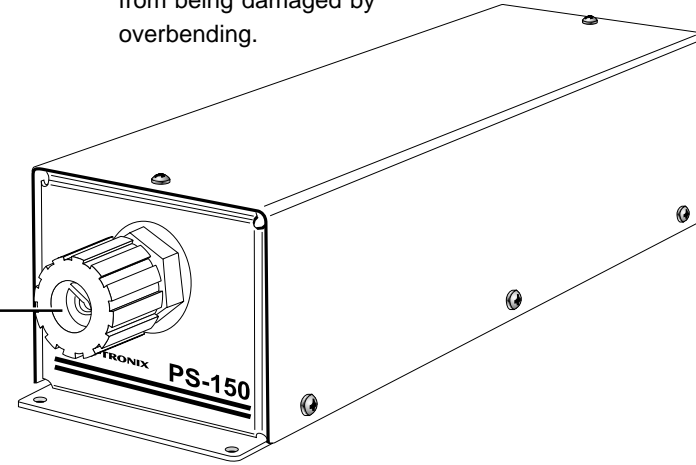

The SC-150 Serial and Control Unit, located in a safe area, receives data from the WI-150 via fiber optic cable and converts the signal to be used by peripheral equipment. Can have up to six cards. Select for present needs and still have room for expanding the system.

- One or two single-port, switch-selectable serial RS-232, RS-422-485, 20 mA current loop input / output cards
- Dual RS-232 / RS-422 / RS-485 card
- Cutoff and parallel input / output card
- Parallel BCD output card
- Analog output card.

Computer

Printer

Other

HAZARDOUS AREA

The battery-powered WI-150 Indicator, its BP-150 Battery Pack, and approved weighing device are located in the hazardous area. The battery-powered WI-150 has a special low-power A to D converter with a one-eighth duty cycle load cell drive to conserve battery life.

The battery pack provides a nominal 8-volt output, current limited to an acceptable output for operation in hazardous areas.

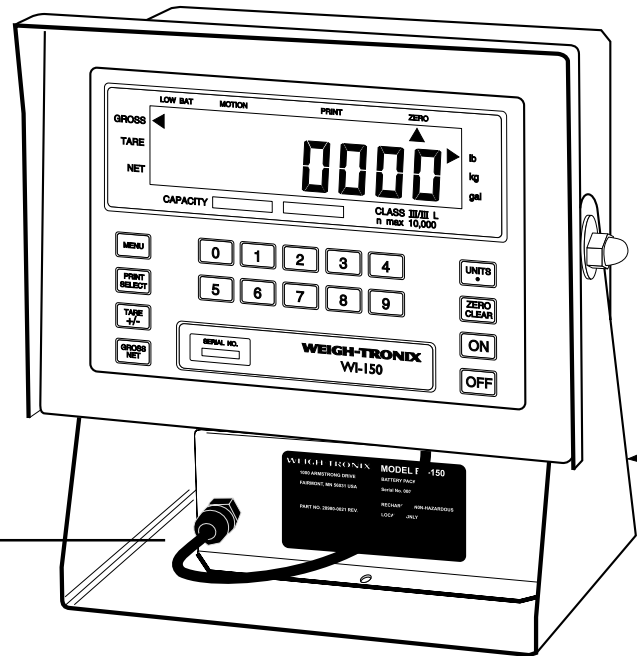

Scale

PS-150 Power Supply, located in the safe area, provides 13.5 volt DC continuous output to the WI-150 Indicator. Voltage and current are limited by the PS-150's Factory Mutual approved barrier.

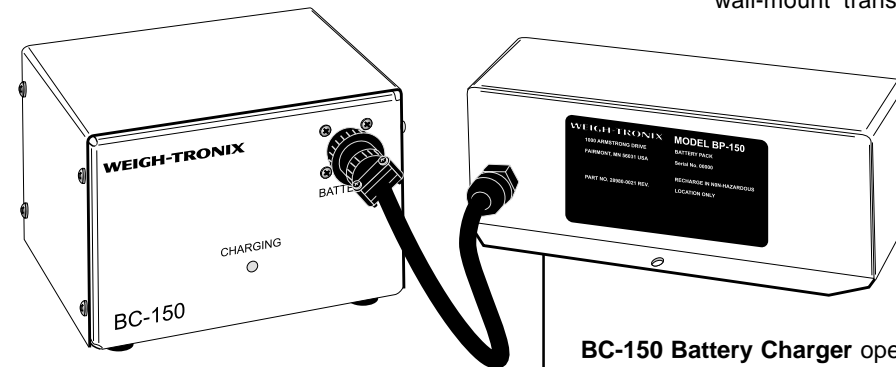

BC-150 Battery Charger operates in the safe area. Its sensor system continuously monitors battery voltage during recharging to prevent over-charging and shortened battery life.

Fiber-Link,

located in the safe area, is a single-function fiber optic converter. Fiber-Link devices include RS-232, RS-422, current loop, cutoff and analog. Power to this circuitry may be supplied from some peripheral instruments or from a wall-mount transformer.

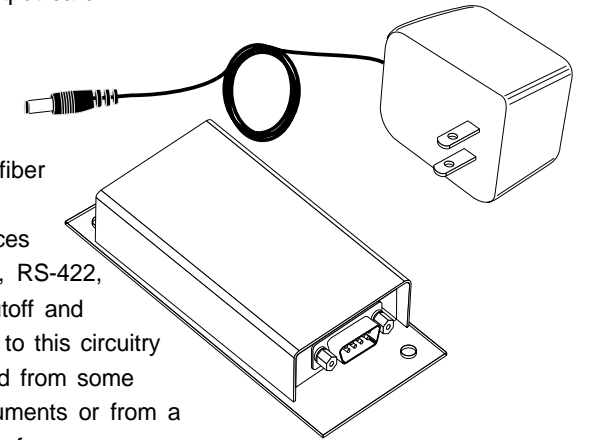

SC-150 Serial & Control Unit

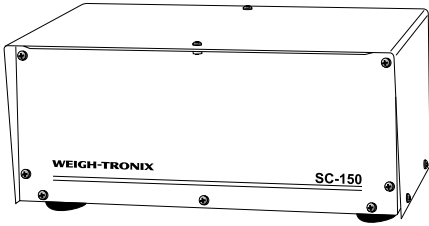

For installations in hazardous environments, the WI-150 Indicator sends data to peripheral equipment via fiber optic cable. The SC-150 Serial and Control Unit, located in a safe area, converts the indicator's digital impulses to output that will communicate with computers, printers, programmable controllers and remote displays. Select the combination of cards you need to complete your system:

- One or two serial input / output cards
- A dual RS-232 / RS-422 / RS-485 card
- A cutoff and parallel input / output card
- A parallel BCD output card
- An analog output card

SC-150 SERIAL & CONTROL UNIT SPECIFICATIONS

Input power:

100 to 130 VAC, 48 to 62 Hz at 100 mA
200 to 260 VAC
48 to 62 Hz at 60 mA

Circuit protection:

Internal fuse, 1/4 amp at 115 VAC, 1/8 amp at 230 VAC

Fiber optics cable length:

250 feet maximum

SERIAL I/O CARD SPECIFICATIONS

Serial I/O card provides a single serial port, four cutoff output transistors and two logic level inputs.

Data output:

Switch-selectable serial RS-232, RS-422/485 or 20 mA current loop.

Handshaking:

Hardware ready / busy for RS-232 only. XON / XOFF for RS-232, RS-422/485 and current loop

Baud rates:

110, 300, 600, 1200, 2400, 4800, 9600 and 19,200

Word length:

8 data bits including parity

Parity bit:

Even, odd, logic 1 or logic 0

DUAL SERIAL I/O CARD SPECIFICATIONS

The dual serial I/O card provides two serial ports, programmable for a variety of signal transmission voltage levels, baud rates, parity choices, and custom formatting.

Data output:

Switch-selectable serial RS-232 or RS-422/485

Handshaking:

Hardware ready / busy for RS-232 only. XON / XOFF for RS-232, RS-422/485 and current loop

Baud rates:

110, 300, 600, 1200, 2400, 4800, 9600 and 19,200

Word length:

8 data bits including parity

Parity bit:

Even, odd, logic 1 or logic 0

CUTOFF & PARALLEL I/O CARD SPECIFICATIONS

The cutoff & parallel I/O card provides ten cutoff outputs, six status outputs, and ten command inputs. The cutoff outputs are configurable to be entered as individual ingredient weights or as setpoints (total displayed weight).

Relay power:

No relay power is provided by the SC-150

Cutoff outputs:

10 open drain MOS field effect transistors switching to ground
Voltage: +60 volts DC max
Current: 200 mA max
On resistance: 7.5 ohms max
Inductive kick protection:
Fly back diodes on all outputs

Status outputs:

Six open drain MOS field effect transistors switching to ground.

Status signals:

Stable, Net, Gross, Center of zero, and Alright

Command inputs:

Zero, Net, Gross, Push-button tare, Print, plus five additional inputs

Logic "1" voltage level:

+3.5 to +5.0 volts

Logic "0" voltage level:

0.0 to +1.5 volts

Low level input current: -0.5 mA

PARALLEL BCD OUTPUT CARD SPECIFICATIONS

The parallel BCD output card provides 5-1/4 decades of data that may be used to interface printers or programmable controllers when a serial interface is not desirable.

Interface signals:

HC MOS 5-volt logic levels

Input / output lines:

- Enable control line
- Data change inhibit input
- Weight data output
- Plus and minus sign output
- Pounds and kilograms output
- Gross and net output
- Printer inhibit output
- Valid data output
- Motion output
- BCD print input
- Remote print output

ANALOG OUTPUT CARD SPECIFICATIONS

The analog output card employs a digital-to-analog converter to provide switch-selectable isolated outputs.

Input power:

10 to 13 VAC, 48 to 62 Hz at 250 mA

Output signals:

DIP switch selectable, 1 to 5 mA, 4 to 20 mA, 10 to 50 mA, 0 to +5 volts or 0 to +10 volts

Isolation:

Analog output is isolated via opto isolator and the low voltage isolation power transformer

Resolution:

More than 21,845 divisions represent zero to full scale range.

Under range: -25% of full capacity

Over range: +25% of full capacity

Fiber-Link, single fiber optics converter

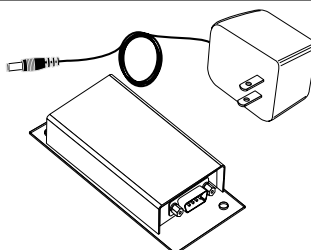

Located in the safe area, the Fiber-Link is a single function fiber optic converter. Fiber-Link devices include RS-232, RS-422, current loop, cutoff and analog. Use up to three Fiber-Links in an installation: One RS-232 or RS-422 or current loop plus analog and/or cutoff.

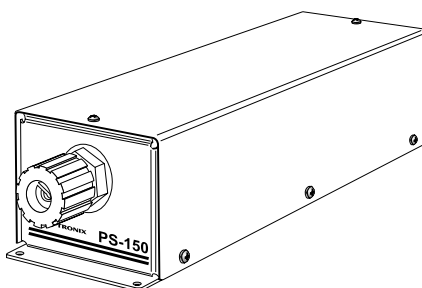

PS-150 Power Supply with Barrier

Located in the safe area of a hazardous environment installation, the PS-150 115 / 230 VAC Power Supply with Barrier provides DC output to the WI-150 Indicator.

Output:

13.5 volt DC, voltage and current limited by a Factory Mutual approved barrier.

Entity parameters:

For Division 1, Class I, Groups A, B, C, D, E, F, G:
Ca equal or less than 0.4 uF
La equal or less than 0.18 mH
Voc equals +18.2 V
ISC equals 435.4 mA

Maximum cable length: 900 feet

BP-150 Rechargeable Battery Pack

The BP-150 Battery Pack for the WI-150 provides a nominal 8-volt output that is current-limited to an acceptable level for use in hazardous area application. Weigh-Tronix recommends the PS-150XP or PS-150 power source when the WI-150 Indicator is linked with Fiber-Links or the SC-150.

Battery life is a function of the battery, the number of weight sensors, and the total time the scale is active versus asleep. For example:

Four 350 ohm weight sensors, 95% of time in sleep mode:
1870-hour battery life

Four 350 ohm weight sensors, 50% of time in sleep mode:
530-hour battery life.

Four 350 ohm weight sensors, no sleep mode:
295-hour battery life

Four 350 ohm weight sensors, no sleep mode, linked to SC-150:
136-hour battery life

Ampere-hour capacity:
5.2 ampere-hours

Nominal open circuit voltage:
8.0 volts

Current limiting resistance:
16.5 ohms

Remote voltage sensing:
Provided through 1000 ohm resistor.

Enclosure:
NEMA 4, water tight stainless steel
8 1/2" x 3" x 3" (21.6 cm x 7.6 cm x 7.6 cm)

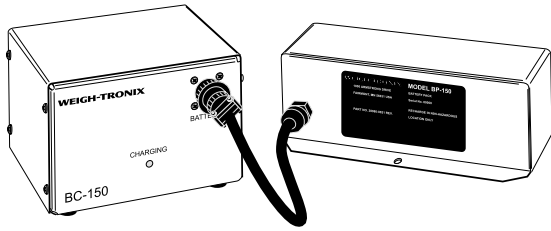

BC-150 Battery Charger

Designed to recharge the 8-volt BP-150 battery pack. The battery charger pays for itself rapidly; its sensor system continuously monitors the battery voltage. Overcharging a battery greatly reduces battery life. The BC-150 battery charger recharges batteries quickly and will not overcharge, even when batteries are left "on charge" indefinitely.

Input power:

100 to 130 VAC 50/60 Hz at .25 ampere
200 to 260 VAC 50/60 Hz at .12 ampere

Circuit protection:

Fuse, 0.5 ampere at 115 VAC,
.25 ampere at 230 VAC

Charging circuit:

Two-step constant current with
remote voltage sensing

Current charge: 520 milliamperes

Float current: 10.4 milliamperes

Automatic charge / float control:

When battery voltage exceeds 9.93 volts, the unit switches to float. When the battery voltage drops to less than 9.27 volts, the unit switches to charge.

Remote voltage

sensing input resistance:

300K ohms

Recharge time:

14 hours typical for 90%
discharged battery.

Weigh Bars® for Hazardous environment installations

Weigh-Tronix has a wide range of Weigh Bars that have been approved by Factory Mutual for hazardous installations. With approved capacities from 30 to 200,000 pounds, Weigh-Tronix offers more than 80 models of Weigh Bars for truck scales; bench and deck scales; bin, tank and hopper scales; and batching applications.

Factory Mutual Control
Document #29274

provides a list of all approved weight sensors and junction boxes compatible with the WI-150 Indicator.



All Weigh-Tronix products bearing the Factory Mutual seal are designed and manufactured according to the guidelines set forth by Factory Mutual Research. It is the responsibility of owners to gain approval from their insurance company for the suitability of the Weigh-Tronix equipment and installation for their particular environment.

Weigh-Tronix assumes no responsibility or liability either expressed or implied for the suitability of the Weigh-Tronix equipment for the owners' specific application or environment.



Weigh-Tronix

1000 Armstrong Dr.
Fairmont, MN 56031 USA
Telephone: 507-238-4461
Facsimile: 507-238-4195
e-mail: industrial@weigh-tronix.com
www.wtxweb.com

Weigh-Tronix Canada, ULC

217 Brunswick Blvd.
Pointe Claire, QC H9R 4R7 Canada
Telephone: 514-695-0380
Facsimile: 514-695-6820

WEIGH-TRONIX

Weighing Products & Systems

WEIGH-TRONIX

The PS-150 XP can be installed in the hazardous areas and will supply the WI-150 indicator with safe, continuous DC power.

The unit is Factory Mutual approved for Class I, II, III, Division 1, Groups B, C, D, E, F, G.



PS-150 XP
Explosion Proof Power Supply for the WI-150

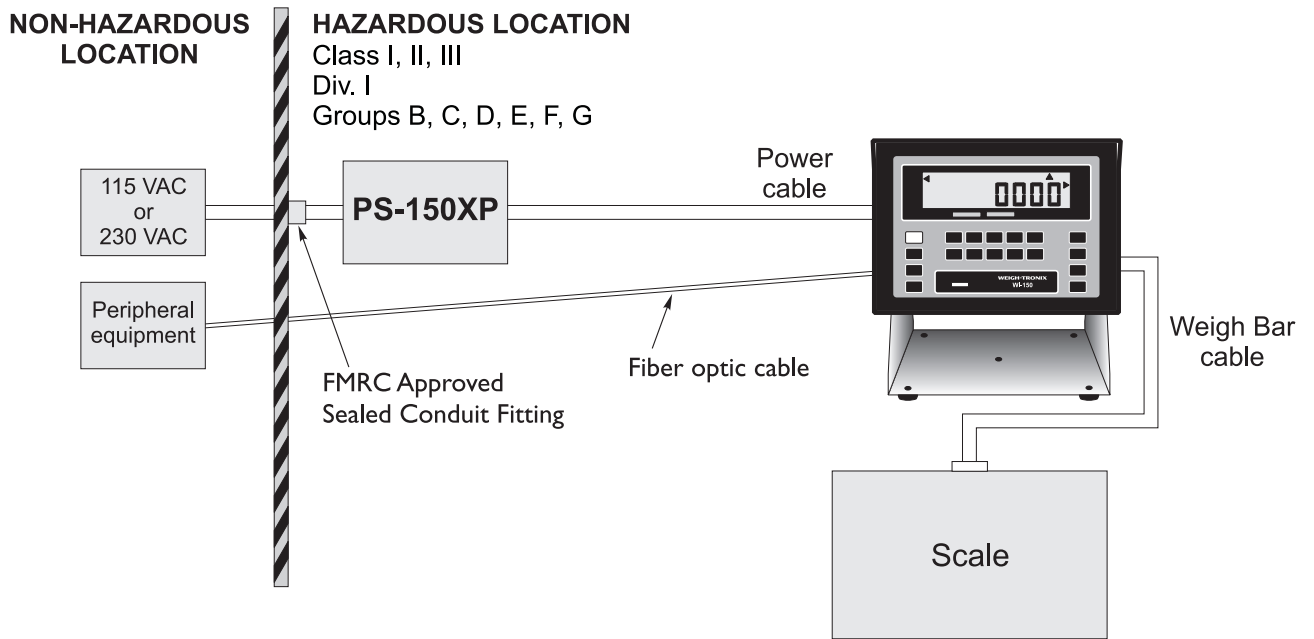

The PS-150 XP receives 115 or 230 VAC via a rigid metal conduit. This PS-150 XP power supply is Factory Mutual approved for Class I, Division I, Groups B, C, D; Class II, Division I, Groups E, F, G and Class III, Division I locations. The PS-150 XP can be installed in these hazardous areas and will supply the WI-150 indicator with continuous DC power. Continuous power eliminates battery hassles and is beneficial for communications with on-line peripheral options.

All Weigh-Tronix products bearing the Factory Mutual seal are designed and manufactured according to the guidelines set forth by Factory Mutual Research.

It is the responsibility of owners to gain approval from their insurance company for the suitability of the Weigh-Tronix equipment and installation for their particular environments.

Weigh-Tronix assumes no responsibility or liability, either expressed or implied, for the suitability of the Weigh-Tronix equipment for the owners specific application or environment.

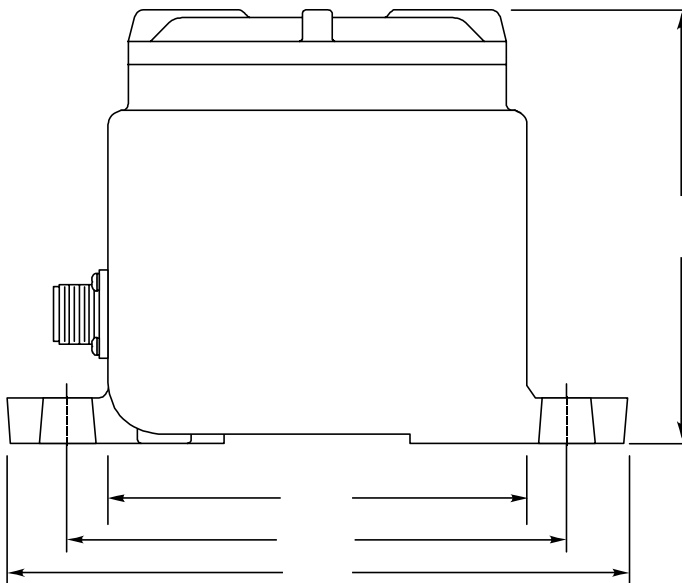

Weigh-Tronix

1000 Armstrong Dr.
Fairmont, MN 56031 USA
Telephone: 507-238-4461
Facsimile: 507-238-4195
e-mail: industrial@weigh-tronix.com
www.weigh-tronix.com

Weigh-Tronix Canada, ULC

217 Brunswick Blvd.
Pointe Claire, QC H9R 4R7 Canada
Telephone: 514-695-0380
Facsimile: 514-695-6820

WEIGH-TRONIX

Weighing Products & Systems